

GC9800iW 20-50

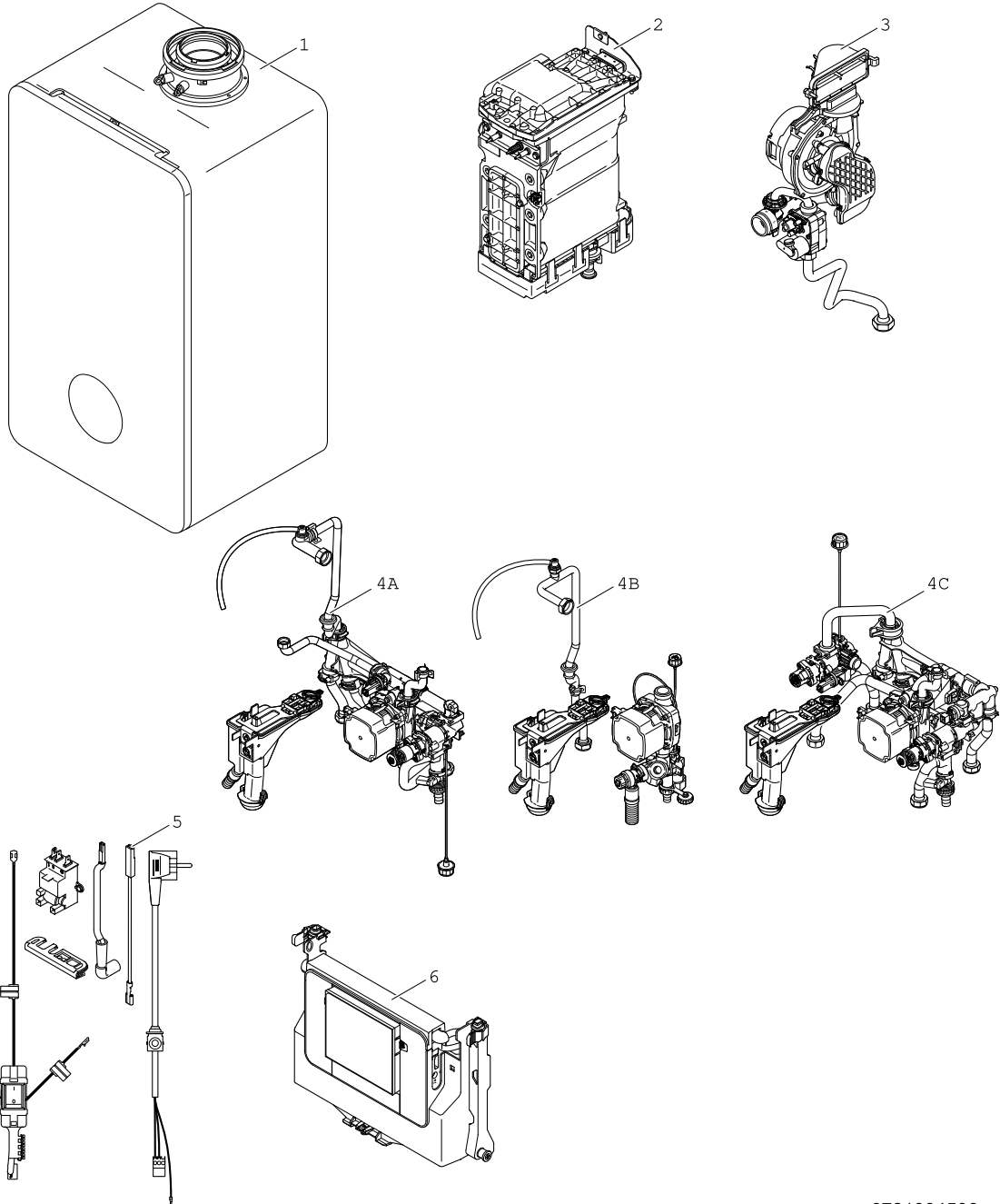

6721904506.ac

[de] Wichtige Hinweise zur Installation/Montage

Die Installation/Montage muss durch eine für die Arbeiten zugelassene Fachkraft unter Beachtung der geltenden Vorschriften erfolgen.

[en] Important notes on installation/assembly

The installation/assembly must be carried out by a qualified contractor, following these instructions and in compliance with the applicable regulations.

[fr] Instructions importantes pour l'installation/le montage

L'installation/le montage doit être effectué(e) par un spécialiste qualifié pour les opérations concernées et dans le respect de la présente notice et des prescriptions applicables.

[bg] Важни указания във връзка с инсталацията/монтажа

Инсталацията/монтажът трябва да се извършва от лицензиран за работите специалист в съответствие с настоящото ръководство и с приложимите разпоредби.

[cs] Důležité pokyny k instalaci/montáži

Instalaci/montáž musí při dodržení pokynů uvedených v tomto návodu a platných předpisů provést odborný pracovník s příslušným oprávněním pro tyto práce.

[da] Vigtige anvisninger til installationen/monteringen

Installationen/monteringen skal foretages af en godkendt installatør under overholdelse af denne vejledning og de gældende forskrifter.

[el] Σημαντικές υποδείξεις για την εγκατάσταση/συναρμολόγηση

Η εγκατάσταση/τοποθέτηση πρέπει να ανατίθεται σε εκπαιδευμένο για τις συγκεκριμένες εργασίες τεχνικό προσωπικό με τήρηση αυτών των οδηγιών καθώς και των σχετικών προδιαγραφών.

[es] Indicaciones importantes para instalación/montaje

La instalación/el montaje debe realizarla personal especializado que esté autorizado para realizar estos trabajos y que tenga en cuenta estas instrucciones y la normativa vigente.

[et] Olulised juhised paigaldamiseks/montaažiks

Paigaldamist/montaaži tohib läbi viia vaid selleks volitusi omav spetsialist, arvestades kehtivaid nõudeid.

[nl-BE] Belangrijke aanwijzingen betreffende de installatie/montage

De installatie/montage moet worden uitgevoerd door een voor de werkzaamheden geautoriseerde installateur rekening houdend met deze handleiding en de geldende voorschriften.

[fi] Tärkeitä asennus- ja kokoonpano-ohjeita

Näihin töihin hyväksytyyn ammattiasentajan pitää suorittaa asennus- ja kokoonpanotyöt voimassa olevien määräysten mukaisesti.

[hr] Važne upute za Instalaciju/Montažu

Instalacija/montaža mora biti izvedena od strane kvalificiranog stručnog osoblja, poštujući ove Upute i u skladu sa važećim propisima.

[hu] Fontos tudnivalók az installáláshoz/szereléshez

A telepítés/szerelés egy, a munkálatokra felhatalmazott szakemberek kell végeznie, jelen utasítás és az érvényes előírások figyelembevételével.

[it] Avvertenze importanti per l'installazione/il montaggio

L'installazione/il montaggio deve aver luogo ad opera di una ditta specializzata ed autorizzata in osservanza di queste istruzioni e delle direttive vigenti.

[ka] მნიშვნელოვანი მითითებები ინსტალაციისთვის/მონტაჟისთვის

ინსტალაცია/მონტაჟი უნდა განხორციელდეს სამუშაოებისთვის დაშვებული კვალიფიციური პერსონალის მიერ, მოქმედი განაწესის დაცვით.

[lt] Svarbios instaliavimo ir (arba) montavimo nuorodos

Instaliavimo/montavimo darbus, laikydamiesi šios instrukcijos reikalavimų ir galiojančių taisyklių, privalo atlikti šioms darbams įgalioti specialistai.

[sq] Shënime të rëndësishme për instalimin/montimin

Instalimi/montimi duhet të bëhet nga një kontraktues i kualifikuar, duke ndjekur këto udhëzime dhe në përputhje me rregulloret në fuqi.

[lv] Svarīgi norādījumi par iekārtas uzstādīšanu / montāžu

Uzstādīšanu/montāžu jāveic atbilstošajiem darbiem sertificētam speciālistam, ievērojot šo instrukciju un spēkā esošos noteikumus.

[nl] Belangrijke aanwijzingen betreffende de installatie/montage

De installatie/montage moet door een erkend installateur volgens de geldende voorschriften worden uitgevoerd.

[no] Viktig informasjon om installasjon/montering

Installasjonen/monteringen skal gjennomføres av autoriserte installatører, og installasjonsanvisningen samt gjeldende forskrifter skal følges.

[pl] Ważne wskazówki dotyczące instalacji/montażu

Instalację/montaż powinien wykonać specjalista uprawniony do tego typu prac z uwzględnieniem informacji podanych w niniejszej instrukcji oraz aktualnie obowiązujących przepisów.

[pt] Indicações importantes relativas à instalação/montagem

A instalação/montagem deve ser efectuada por um técnico autorizado para os trabalhos, respeitando este manual e as prescrições válidas.

[ro] Indicații importante privind instalarea/montajul

Instalarea/montajul trebuie realizate de către un specialist autorizat pentru lucrările respective, respectându-se prezentele instrucțiuni și prescripțiile valabile.

[ru] Важные указания по подключению/монтажу

Подключение/монтаж должны выполнять только специалисты, имеющие допуск к выполнению таких работ, при соблюдении требований этой инструкции и действующих норм и правил.

[sk] Dôležité pokyny týkajúce sa inštalácie/montáže

Inštaláciu/montáž musí vykonať odborný personál, ktorý má oprávnenie pre výkon týchto prác, pričom musí dodržiavať pokyny uvedené v tomto návode a platné predpisy.

[sl] Pomembni napotki za namestitvev/montažo

Inštalacijo/montažo lahko izvede samo pooblaščen strokovnjak ob upoštevanju teh navodil in veljavnih predpisov.

[sr] Važna uputstva za ugradnju i montažu

Ovu instalaciju/montažu moraju da obave stručna lica koja su ovlašćena za obavljanje takvih radova u skladu sa ovim uputstvom i važećim propisima.

[sv] Viktiga anvisningar för installation/montering

Installationen/monteringen måste utföras av en behörig och tekniskt utbildad person enligt denna anvisning samt gällande föreskrifter.

[tr] Kurulum/Montaj ile ilgili önemli uyarılar

Kurulum/montaj, bu çalışmaları yapmasına müsaade edilen uzman kişiler tarafından işbu kılavuz ve geçerli yönetmelikler dikkate alınarak yapılmalıdır.

[uk] Важливі вказівки щодо установки/монтажу

Встановлення/монтаж повинні виконувати фахівці, що допущені до виконання таких робіт, із дотриманням цієї інструкції та діючих приписів.

[zh] 安装方面的重要提示

安装和组装工作必须由经过许可的专业人员进行，同时必须遵守本说明书和现行法规的相关要求

[ar] ملاحظات هامة للتجميع

يجب أن يتم التجميع من قبل متخصص مصرح له بالعمل، مع مراعاة اللوائح السارية.

[fa] تذکرات مهم درباره نصب/مونتاژ

نصب/مونتاژ باید توسط فردی حرفه ای که مجاز به انجام این کار است، و همچنین با توجه کامل به مقررات مربوطه انجام شود.

[az] Quraşdırılma

Quraşdırılma işinin yerinə yetirilməsi səlahiyyətli bir mütəxəssis tərəfindən və müvafiq qaydalara uyğun olaraq aparılmalıdır.

Ersatzteilliste
Spare parts list

Liste des pièces de rechange
Lista parti di ricambio

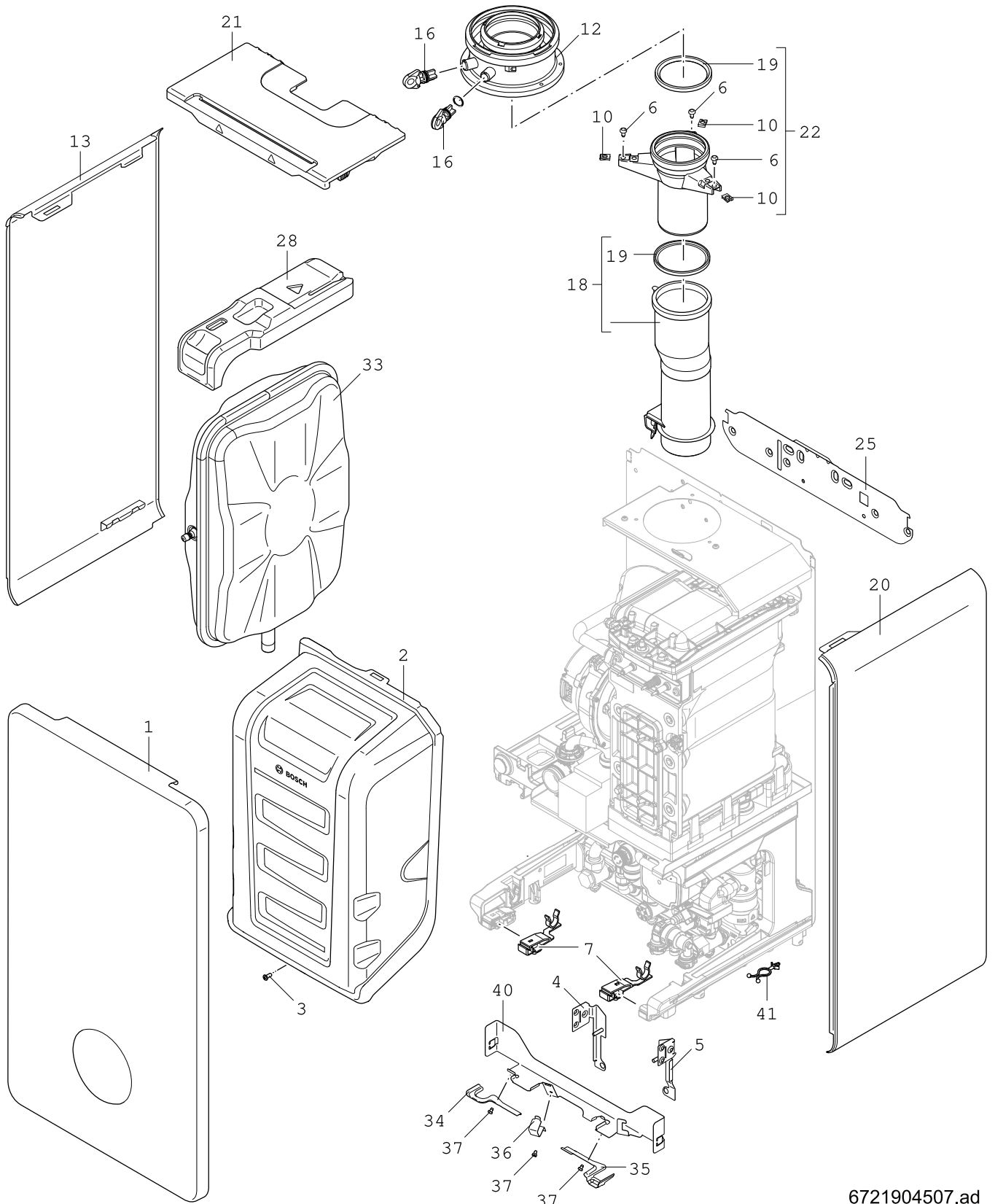

6721904507.ad

1
Gehäuse
Casing
Carter
Involucro

GC9800iW 20-50

Ersatzteilliste
Spare parts list

Liste des pièces de rechange
Lista parti di ricambio

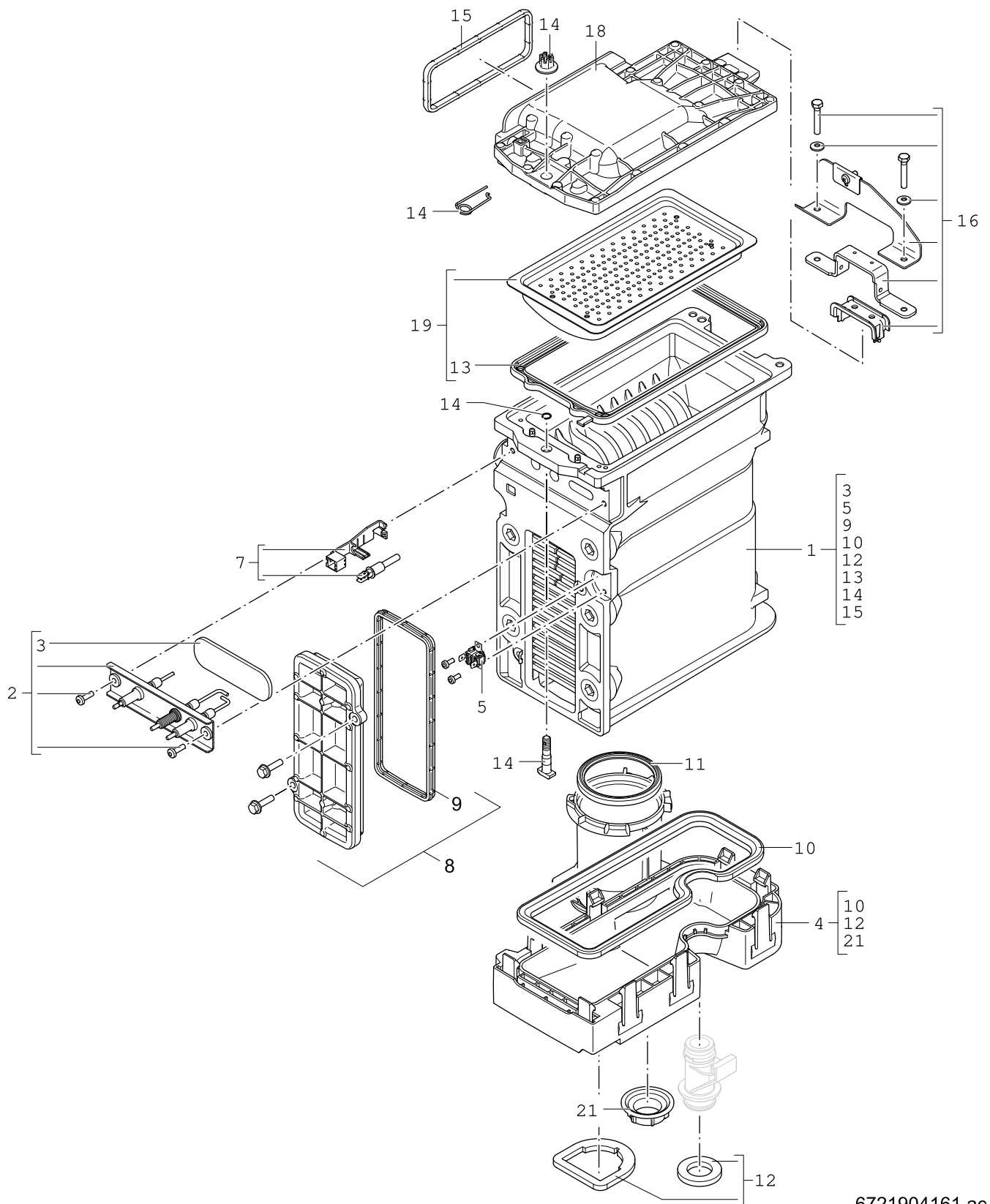

6721904161.ac

2

Wärmetauscher
Heat exchanger
Échangeur thermique
Scambiatore di calore

GC9800iW 20-50

Pos	Bezeichnung Description Dénomination Descrizioni	Bestell-Nr. Ordering no. Numéro de commande N° d'ordine	7-738-101-024	7-738-101-025	7-738-101-026	7-738-101-027	7-738-101-028	7-738-101-029	7-738-101-030	7-738-101-031	7724002658	7724002659							Bemerkungen Remarks Remarques Osservazioni
1	Wärmetauscher WB5-IV	8 737 712 170								■									
1	Wärmetauscher WB5-II+	8 737 712 171	■	■	■	■	■	■	■	■	■	■							
2	Elektroden-Set	8 718 663 092 0	■	■	■	■	■	■	■	■	■	■							
3	Dichtung (Elektrode) Insulfrax (10x)	8 737 708 824	■	■	■	■	■	■	■	■	■	■							
4	Kondensatwanne	8 737 708 872	■	■	■	■	■	■	■	■	■	■							
5	Temperaturbegrenzer	8 737 712 163	■	■	■	■	■	■	■	■	■	■							
7	Temperaturfühler NTC	8 714 500 087 0	■	■	■	■	■	■	■	■	■	■							
8	Wartungsdeckel WB5-II+	8 718 666 172 0	■	■	■	■	■	■	■	■	■	■							
8	Wartungsdeckel WB5-IV	8 718 666 173 0								■									
9	Dichtung (Wartungsdeckel) WB5-II+	8 710 103 153 0	■	■	■	■	■	■	■	■	■	■							
9	Dichtung (Wartungsdeckel) WB5-IV	8 737 701 450 0								■									
10	Kondensatwannen-Dichtung	8 710 103 155 0	■	■	■	■	■	■	■	■	■	■							
11	Dichtung Ø 87,5mm	8 722 933 330 0	■	■	■	■	■	■	■	■	■	■							
12	Dichtungs-Set	8 737 709 150	■	■	■	■	■	■	■	■	■	■							
13	Dichtung Brenner WB5-II+ CMS <=42kW	8 718 668 064 0	■	■	■	■	■	■	■	■	■	■							
13	Dichtung Brenner WB5-II+ >=45kW	8 737 701 854 0								■									
14	Hammerkopfschraube M8x42	8 737 712 757	■	■	■	■	■	■	■	■	■	■							
15	Dichtung (Gas-Luft-Kanal)	8 737 701 451 0	■	■	■	■	■	■	■	■	■	■							
16	Halterung	8 718 665 043 0	■	■	■	■	■	■	■	■	■	■							
16	Halterung	8 737 700 018 0								■									
18	Brennerdeckel WB5-IV	8 718 662 858 0								■									
18	Brennerdeckel WB5-II+	8 737 707 981	■	■	■	■	■	■	■	■	■	■							
19	Brenner WB5-IV	8 737 701 860 0								■									
19	Brenner WB5-II+	8 737 706 604 0	■	■	■	■	■	■	■	■	■	■							
21	Mutter	8 713 301 196 0	■	■	■	■	■	■	■	■	■	■							
	Service-Set (Wärmetauscher)	8 737 708 542	■	■	■	■	■	■	■	■	■	■							
	Service-Set (Wärmetauscher)	8 737 708 671								■									

GC9800iW 20-50

Wärmetauscher
Heat exchanger
Échangeur thermique
Scambiatore di calore

2

Ersatzteilliste
Spare parts list

Liste des pièces de rechange
Lista parti di ricambio

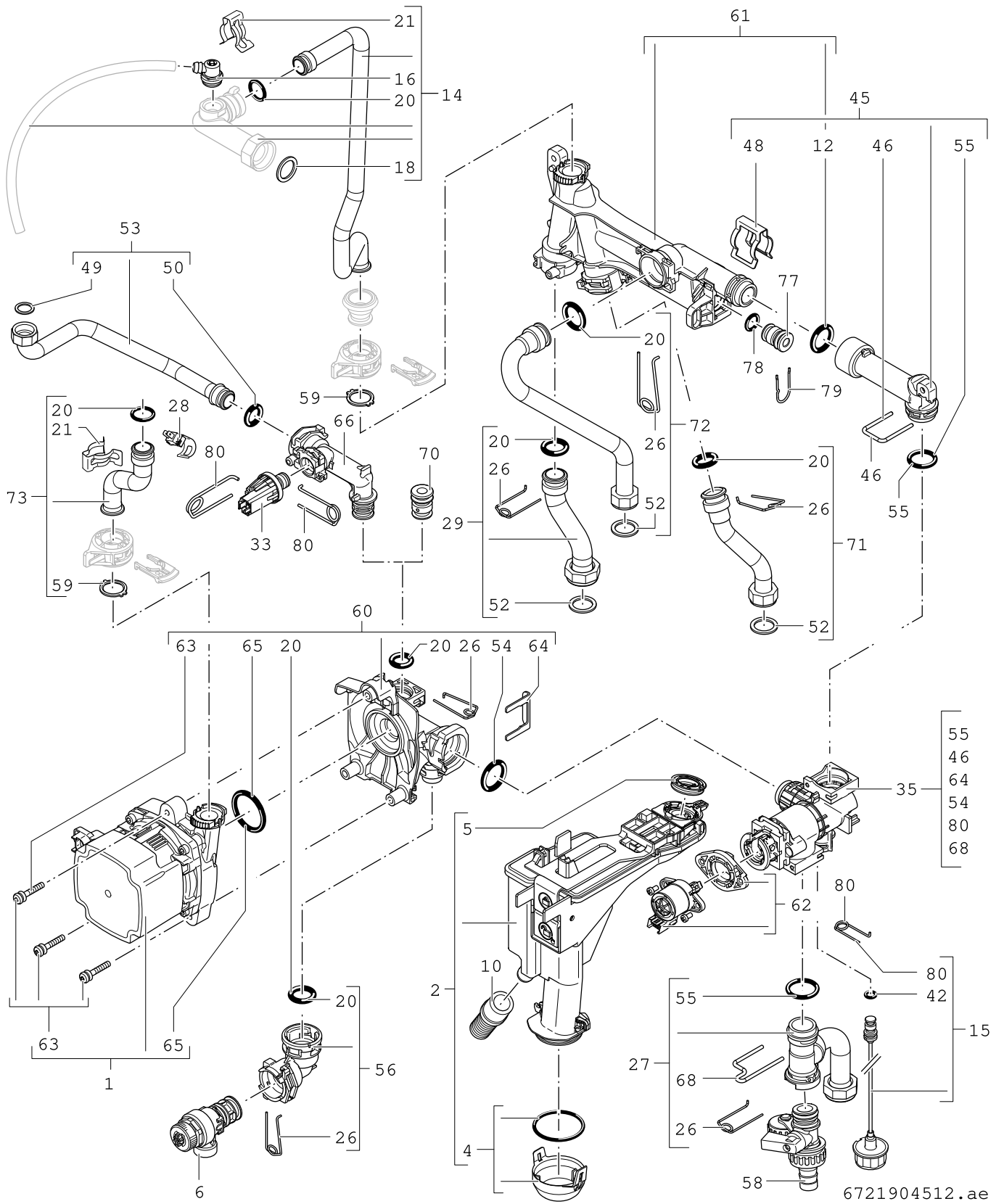

4A

Hydraulik U02-10 System
Hydraulics U02-10 System
Hydraulique U02-10 System
Idraulica U02-10 System

GC9800iW 20-50

6721904512.ae

Ersatzteilliste
Spare parts list

Liste des pièces de rechange
Lista parti di ricambio

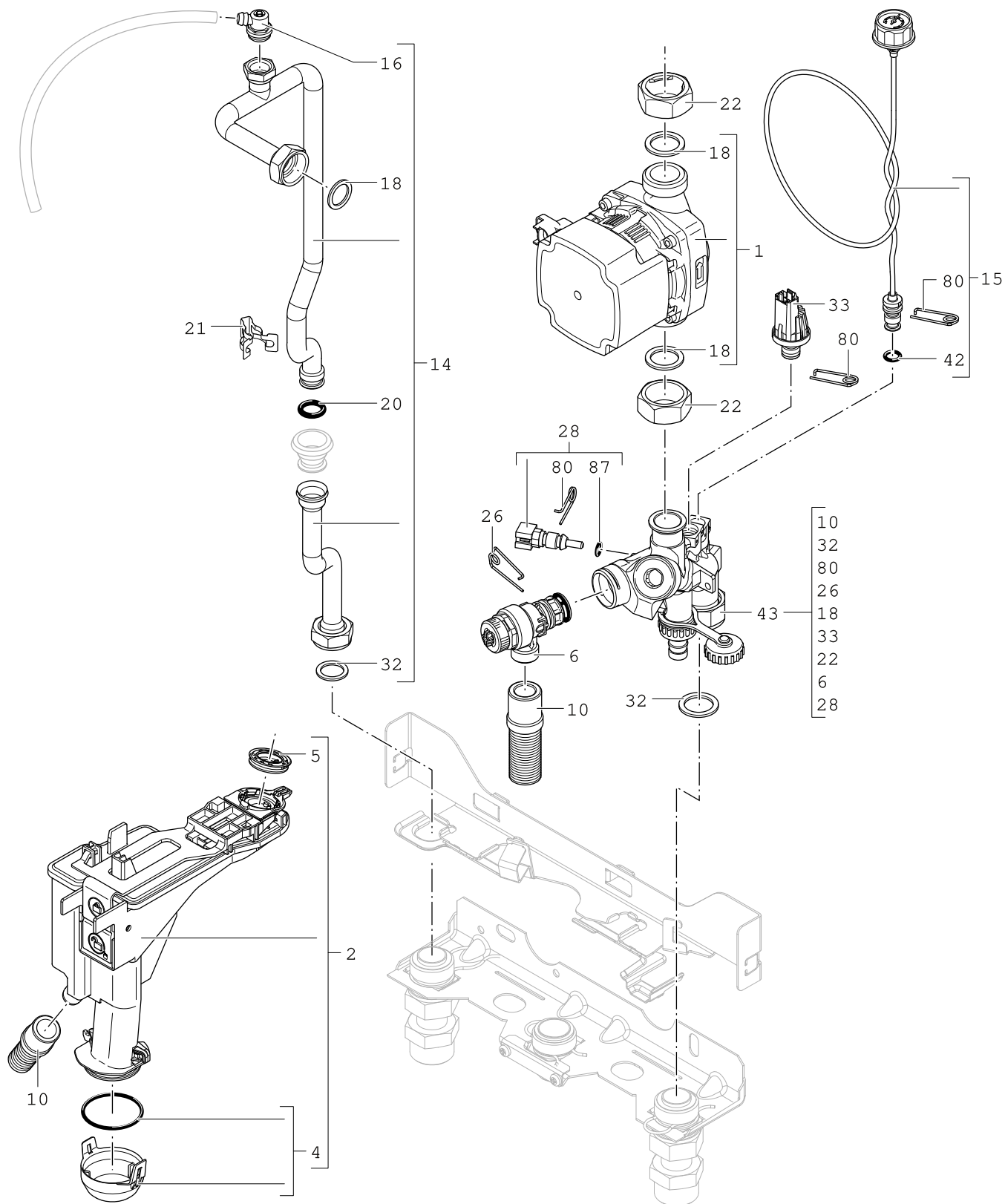

6721904896.ac

4B

Hydraulik U02-90 Heating only
Hydraulics U02-90 Heating only
Hydraulique U02-90 Heating only
Idraulica U02-90 Heating only

GC9800iW 20-50

Pos	Bezeichnung Description Dénomination Descrizioni	Bestell-Nr. Ordering no. Numéro de commande N° d'ordine	7-738-101-024	7-738-101-025	7-738-101-026	7-738-101-027	7-738-101-028	7-738-101-029	7-738-101-030	7-738-101-031	7724002658	7724002659							Bemerkungen Remarks Remarques Osservazioni
1	Pumpe UPM4L 68W ErP1 (Gusseisen)	8 737 605 868					■	■											
1	Pumpe UPM4L 75W ErP1 (Gusseisen)	8 737 605 870							■	■									
2	Siphon	8 737 709 163					■	■	■	■									
4	Deckel	8 737 709 166					■	■	■	■									
5	Dichtung	8 737 602 313					■	■	■	■									
6	Sicherheitsventil	8 718 643 989 0					■	■	■	■									
10	Ablaufschlauch	8 737 712 737					■	■	■	■									
14	Vorlaufrohr (2-teilig)	8 737 713 751								■									
14	Vorlaufrohr	8 737 713 752					■	■	■										
15	Manometer	8 737 712 661					■	■	■	■									
16	Entlüfter	8 717 405 285 0					■	■	■	■									
18	Dichtung 22,2x30x2	8 737 709 162					■	■	■	■									
20	O-Ring 17x4 L (10x)	8 716 771 154 0					■	■	■	■									
21	Klammer (10x)	8 711 200 024 0					■	■	■	■									
22	Überwurfmutter	7 099 416					■	■	■	■									
26	Haltefeder 18mm (10x)	8 718 684 699 0					■	■	■	■									
28	Temperaturfühler	8 714 500 081 0					■	■	■	■									
32	Dichtung 30x25x1,5 (10x)	8 710 103 014 0					■	■	■	■									
33	Druckfühler	8 718 651 042 0					■	■	■	■									
42	O-Ring 2,62x6,02 WRAS / KTW (10x)	8 716 140 810 0					■	■	■	■									
43	Anschlussstück Rücklauf	8 737 713 747					■	■	■	■									
80	Haltefeder 10mm (10x)	8 716 771 167 0					■	■	■	■									
87	O-Ring 7,75x2,1 (10x)	8 710 205 080 0					■	■	■	■									

GC9800iW 20-50

Hydraulik U02-90 Heating only
 Hydraulics U02-90 Heating only
 Hydraulique U02-90 Heating only
 Idraulica U02-90 Heating only

4B

Ersatzteilliste
Spare parts list

Liste des pièces de rechange
Lista parti di ricambio

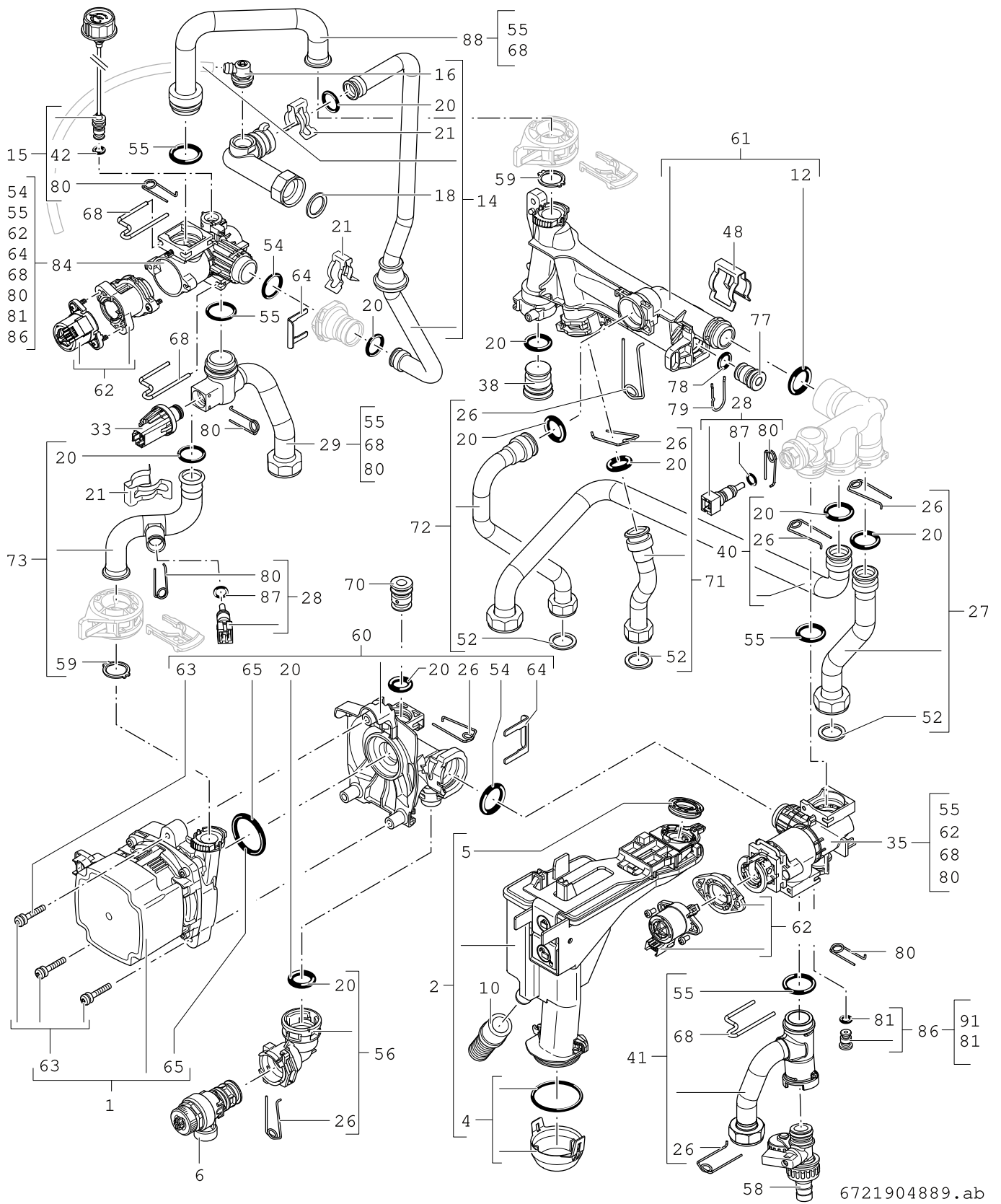

6721904889.ab

4C

Hydraulik U02-50 WA
Hydraulics U02-50 WA
Hydraulique U02-50 WA
Idraulica U02-50 WA

GC9800iW 20-50

Ersatzteilliste
Spare parts list

Liste des pièces de rechange
Lista parti di ricambio

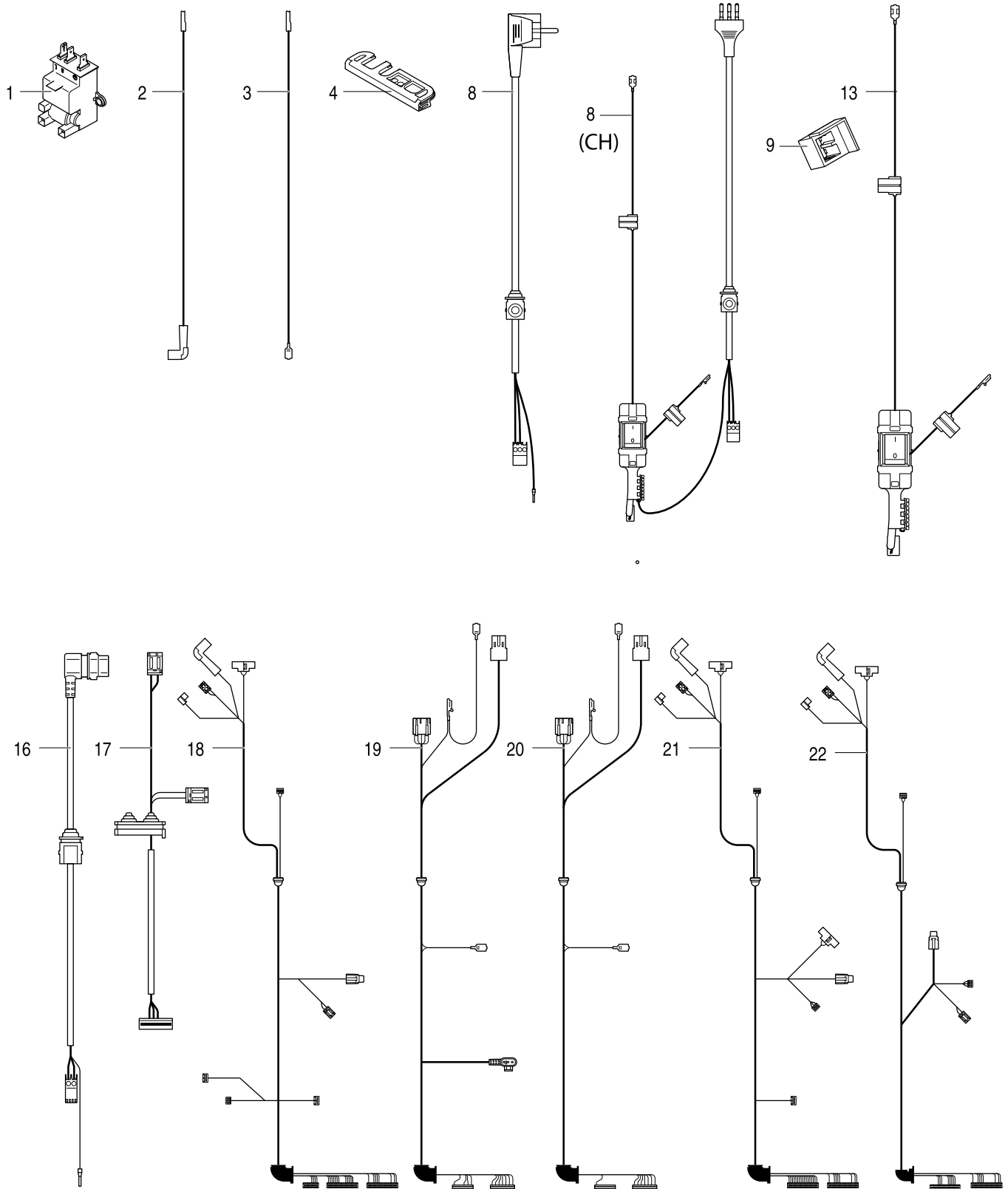

6721904513.af

5 Kabelbaum
Cable harness
Faisceau de câbles
Cablaggio

GC9800iW 20-50

Pos	Bezeichnung Description Dénomination Descrizioni	Bestell-Nr. Ordering no. Numéro de commande N° d'ordine	7-738-101-024	7-738-101-025	7-738-101-026	7-738-101-027	7-738-101-028	7-738-101-029	7-738-101-030	7-738-101-031	7724002658	7724002659							Bemerkungen Remarks Remarques Osservazioni
1	Zündtrafo	7 736 700 599	■	■	■	■	■	■	■	■	■	■							
2	Zündleitung	8 737 712 818	■	■	■	■	■	■	■	■	■	■							
3	Masseleitung L 140mm	8 737 712 819	■	■	■	■	■	■	■	■	■	■							
4	Tülle (Kabelführung)	8 737 710 236	■	■	■	■	■	■	■	■	■	■							
8	Netzleitung	8 737 712 655	■	■	■	■	■	■	■	■	■	■							
8	Netzleitung	8 738 906 096									■	■							
9	Manschette	8 738 901 772	■	■	■	■	■	■	■	■	■	■							
13	Leitung + Schalter ON/OFF	8 737 711 282	■	■	■	■	■	■	■	■	■	■							
16	Pumpenkabel	8 737 713 938								■	■								
17	Kabelbaum LV	8 737 713 929			■	■													
18	Kabelbaum LV	8 737 713 930			■	■													
19	Kabelbaum HV	8 737 713 159	■	■							■	■							
20	Kabelbaum HV	8 737 713 161					■	■	■	■									
21	Kabelbaum LV	8 737 713 936	■	■							■	■							
22	Kabelbaum LV	8 737 713 937					■	■	■	■									

GC9800iW 20-50

Kabelbaum
Cable harness
Faisceau de câbles
Cablaggio

5

Ersatzteilliste
Spare parts list

Liste des pièces de rechange
Lista parti di ricambio

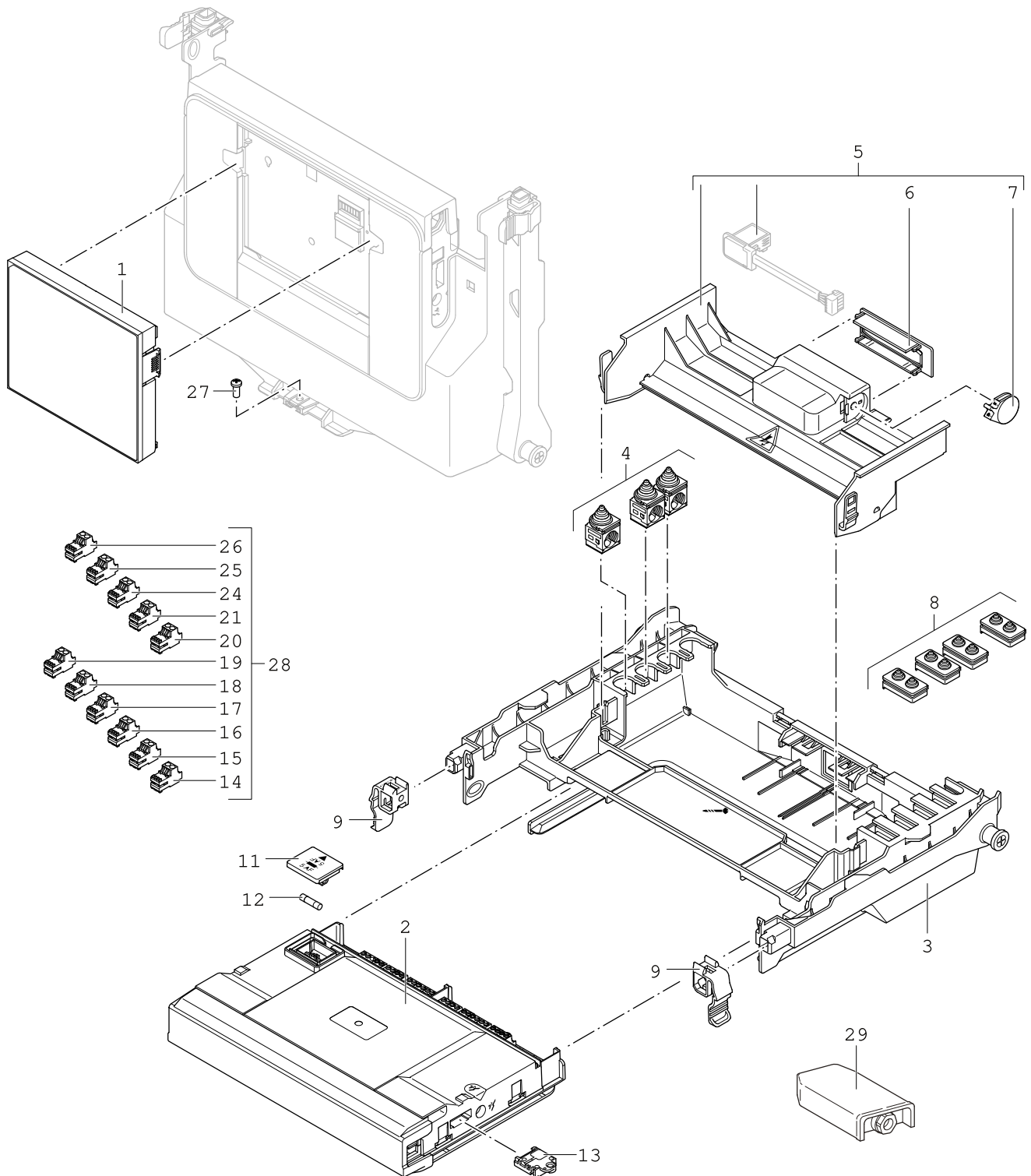

6721904514.ab

6 Bedienelement
Control panel
Unité de commande
Interfaccia controllo

GC9800iW 20-50

Übersetzungsliste
List of translations

Liste des traductions
Traduzione delle descrizioni

Pos	Description	Description	Descrizione		
1	Element of construction	Groupe d'assemblage	Gruppo di montaggio		
1	Front panel Bosch (white)	Panneau avant Bosch (blanc)	Pannello Bosch (bianco)		
2	Air box Bosch	Caisson Bosch	Camera ventilazione Bosch		
3	Screw M5x12 (10x)	Vis M5x12 (10x)	Vite M5x12 (10x)		
4	Bracket (left)	Support (gauche)	Supporto (sinistro)		
5	Bracket (right)	Support (droit)	Supporto (destro)		
6	Screw 4.8x13 ISO 14585 (10x)	Vis 4.8x13 ISO 14585 (10x)	Vite 4.8x13 ISO 14585 (10x)		
7	Fastener	Étrier de serrage	Gancio di chiusura		
10	Clip 4,8mm (10x)	Ecrou en pince 4,8mm (10x)	Dado a scatto 4,8mm (10x)		
12	Flue adapter DN 80/125	Adaptateur des fumées DN 80/125	Adattatore gas di combustione DN 80/125		
13	Side panel (left)	Panneau latéral gauche argenté	Pannello laterale (sinistro)		
16	Plug	Bouchon avec joint	Tappo		
18	Flue Pipe	Tuyau de fumées	Condotto per gas combusti		
18	Flue pipe	Tuyau de fumées	Condotto per gas combusti		
19	Lip Seal DN80	Joint DN80	Guarnizione DN80		
20	Side panel (right)	Panneau latéral droit argenté	Pannello laterale (destro)		
21	Top Panel	Panneau supérieur	Pannello superiore		
22	Flue Outlet	Conduite des gaz d'échappement	Connessione aria/combusti in caldaia		
25	Wall mounting bracket	Plaque d'accrochage	Supporto a parete		
28	Support (Expansion Vessel)	Support (Vase d'expansion)	Supporto (Vaso d'espansione)		
33	Expansion vessel 12L	Vase d'expansion 12L	Vaso di espansione 12L		
34	Bracket (Pipe) (left)	Support (Tube) (gauche)	Supporto (Tubo) (sinistro)		
35	Bracket (Pipe) (right)	Support (Tube) (droit)	Supporto (Tubo) (destro)		
36	Clamp	Collier tube	Fissa tubo		
37	Screw 4,8x9,5 (10x)	Vis 4,8x9,5 (10x)	Vite 4,8x9,5 (10x)		
40	Bracket	Support	Supporto		
41	Cable Tie	Serre-câble	Fascetta stringicavo		
2	Element of construction	Groupe d'assemblage	Gruppo di montaggio		
1	Heat exchanger WB5-IV	Échangeur de chaleur WB5-IV	Scambiatore di calore WB5-IV		
1	Heat exchanger WB5-II+	Echangeur de chaleur WB5-II+	Scambiatore di calore WB5-II+		
2	Electrode kit	Jeu d'électrodes	Set di elettrodi		
3	Gasket (Electrode) Insulfrax (10x)	Joint (Électrode) Insulfrax (10x)	Guarnizione (Elettrodo) Insulfrax (10x)		

Übersetzungsliste
List of translations

Liste des traductions
Traduzione delle descrizioni

Pos	Description	Description	Descrizione		
4	Condensate tray	Collecteur de condensats	Collettore condensa		
5	Temperature limiter	Limiteur de température	Limitatore di temperatura		
7	Temperature sensor NTC	Sonde de température NTC	Sonda di temperatura NTC		
8	Service cover WB5-II+	Couvercle de maintenance WB5-II plus	Copertura per manutenzione WB5-II+		
8	Service cover WB5-IV	Couvercle de maintenance WB5-IV	Copertura per manutenzione WB5-IV		
9	Seal (Service cover) WB5-II+	Joint (Couvercle de maintenance) WB5-II+	Guarnizione (Copertura manutenzione)		
9	Seal (Service cover) WB5-IV	Joint couvercle WB5-IV	Guarnizione (Copertura manutenzione)		
10	Condensate tray collector seal	Joint collecteur de condensats	Guarnizione collettore combusti		
11	Seal Ø 87,5mm	Joint Ø 87,5mm	Guarnizione Ø 87,5mm		
12	Seal Kit	Jeu de joints	Set di guarnizioni		
13	Seal burner WB5-II+ CMS <=42kW	Joint brûleur WB5-II plus CMS <=42kW	Guarnizione bruciatore WB5-II + CMS <		
13	Seal burner WB5-II+ >=45kW	Joint brûleur WB5-II+ >=45kW	Guarnizione bruciatore WB5-II + >=45kW		
14	T-head bolt M8x42	Vis M8x42	Vite M8x42		
15	Seal (Gas-air duct)	Joint canal mélange gaz-air	Guarnizione (Condotto gas-air)		
16	Bracket	Support	Supporto		
18	Burner cover WB5-IV	Capot de brûleur WB5-IV	Coperchio del bruciatore WB5-IV		
18	Burner cover WB5-II+	Capot de brûleur WB5-II+	Coperchio del bruciatore WB5-II+		
19	Burner WB5-IV	Brûleur WB5-IV	Bruciatore WB5-IV		
19	Burner WB5-II+	Brûleur WB5-II+	Bruciatore WB5-II+		
21	Nut	Écrou	Dado		
	Service kit (Heat exchanger)	Jeu de maintenance (Échangeur thermique)	Set di manutenzione (Scambiatore di calo)		
3	Element of construction	Groupe d'assemblage	Gruppo di montaggio		
1	Gas-air duct WB5-II+	Conduit gaz-air WB5-II+	Condotto gas-aira WB5-II+		
1	Gas-air duct WB5-IV	Conduit gaz-air WB5-IV	Condotto gas-aira WB5-IV		
2	Seal (Gas-air duct)	Joint canal mélange gaz-air	Guarnizione (Condotto gas-air)		
3	Sound absorber	Silencieux	Silenziatore		
4	Non-return valve	Clapet anti-retour	Valvola di non ritorno		
5	Lip seal	Joint	Guarnizione		
7	O-ring 63x3 (10x)	Joint torique 63x3 (10x)	O-ring 63x3 (10x)		
8	Mixing unit	Chambre de mélange	Unità di miscelazione		
9	Screw M4x8	Vis M4x8	Vite M4x8		
10	Security seal (Venturi) (10x)	Sceau de sécurité (Venturi) (10x)	Sigillo di sicurezza (Venturi) (10x)		

Übersetzungsliste
List of translations

Liste des traductions
Traduzione delle descrizioni

Pos	Description	Description	Descrizione		
11	Gas pipe	Tube gaz	Tubo del gas		
12	Seal (10x)	Joint (10x)	Guarnizione (10x)		
13	O-ring 12x3 (10x)	Joint torique 12x3 (10x)	O-ring 12x3 (10x)		
14	Gas valve	Bloc gaz	Valvola del gas		
15	Gasket 23,9x17,2x1,5 (10x)	Joint 23,9x17,2x1,5 (10x)	Guarnizione 23,9x17,2x1,5 (10x)		
16	Gasket	Joint	Guarnizione		
17	Gas pipe	Tube gaz	Tubo del gas		
18	Screw M4x8 (10x)	Vis M8x45 (10x)	Vite M4x8 (10x)		
20	Fan	Ventilateur	Ventilatore		
21	Venturi	Venturi	Venturi		
22	Nut M6 + Screw M6x30-5.8	Ecrou + Vis M6x30-5.8	Dado + Vite M6x30-5.8		
24	Cap (Inspection point)	Capuchon	Tappo		
26	Gasket 41x3 (10x)	Joint 41x3 (10x)	Guarnizione 41x3 (10x)		
4A	Element of construction	Groupe d'assemblage	Gruppo di montaggio		
1	Pump UPM4L 68W ErP1	Pompe UPM4L 68W ErP1	Pompa UPM4L 68W ErP1		
2	Siphon	Siphon	Sifone		
4	Cap	Couvercle	Coperchio		
5	Seal	Joint siphon	Guarnizione		
6	Pressure relief valve	Soupape de limitation de pression	Valvola di sicurezza		
10	Drain hose	Tuyau d'évacuation	Tubo flessibile di scarico		
12	O-ring 20,22x3,53 EPDM (10x)	Joint torique 20,22x3,53 EPDM (10x)	O-ring 20,22x3,53 EPDM (10x)		
14	Supply pipe	Tube départ	Tubo di mandata		
15	Pressure Gauge	Manomètre	Manometro		
16	Air vent	Soupape de ventilation	Disaeratore		
18	Gasket 22,2x30x2	Joint 22,2x30x2	Guarnizione 22,2x30x2		
20	O-ring 17x4 L (10x)	Joint torique 17x4 L (10x)	O-ring 17x4 L (10x)		
21	Clip (10x)	Clip pour tuyau (x10)	Clip a innesto (10x)		
26	Clip 18mm (10x)	Épingle 18mm (10x)	Molletta di ritenzione 18mm (10x)		
27	Return pipe CH	Tube retour CH	Tubo di ritorno CH		
28	Temperature Sensor	Sonde de température	Sonda di temperatua		
29	Supply pipe CH	Tube départ CH	Tubo di mandata CH		
33	Pressure Sensor	Capteur de pression	Sonda di pressione		

Übersetzungsliste
List of translations

Liste des traductions
Traduzione delle descrizioni

Pos	Description	Description	Descrizione		
35	3-way valve	Vanne 3 voies	Organo 3 vie		
42	O-ring 2,62x6,02 WRAS / KTW (10x)	Joint torique 2,62x6,02 WRAS / KTW (10x)	O-ring 2,62x6,02 WRAS / KTW (10x)		
45	Connecting pipe	Tube de raccordement	Tubo di collegamento		
46	Clip (10x)	Epingle (10x)	Molletta di ritenzione (10x)		
48	Clip (10x)	Clip (10x)	Clip a innesto (10x)		
49	Gasket 18.6 x 13.5 x 1.5 (1x)	Joint 18.6 x 13.5 x 1.5 (1x)	Guarnizione 18.6 x 13.5 x 1.5 (1x)		
50	O-ring 12,5x3 WRAS / KTW (10x)	Joint torique 12.5x3 WRAS / KTW (10x)	O-ring 12,5x3 WRAS / KTW (10x)		
52	Gasket 23,9x17,2x1,5 (10x)	Joint 23,9x17,2x1,5 (10x)	Guarnizione 23,9x17,2x1,5 (10x)		
53	Pipe (Expansion vessel)	Tube (Vase d'expansion)	Tubo (Vaso d'espansione)		
54	O-ring 23x4 (10x)	Joint torique 23x4 (10x)	O-ring 23x4 (10x)		
55	O-ring 23,47x2,62 (10x)	Joint torique 23,47x2,62 (10x)	O-ring 23,47x2,62 (10x)		
56	Connecting pipe (Pressure relief valve)	Tube de raccordement (Soupape sécurité)	Tubo di collegamento (Valvola sicurezza)		
58	Fill and drain cock	Robinet de remplissage et de vidange	Rubinetto di carico e scarico		
59	Seal 19.9mm (1x)	Joint 19.9mm (1x)	Guarnizione 19.9mm (1x)		
60	Manifold plate (Pump)	Collecteur (Pompe)	Collettore (Pompa)		
61	Manifold	Raccordement	Collegamento		
62	Motor (3-way valve)	Servomoteur (vanne 3 voies)	Motore (Organo 3 vie)		
63	Screw M5x30 + Washer	Vis et joint rondelle M5x30	Vite M5x30 + Rondella		
64	Clip (10x)	Clip (10x)	Clip di fissaggio (10x)		
65	O-ring 34x3 (10x)	Joint torique 34x3 (10x)	O-ring 34x3 (10x)		
66	Manifold (Expansion vessel)	Raccordement (Vase d'expansion)	Collegamento (Vaso d'espansione)		
68	Clip (10x)	Epingle (10x)	Molletta di ritenzione (10x)		
70	Plug 15mm	Bouchon 15mm	Tappo 15mm		
71	Supply pipe DHW	Tube départ DHW	Tubo di mandata DHW		
72	Supply pipe DCW	Tube départ DCW	Tubo di mandata DCW		
73	Return pipe	Tube retour	Tubo di ritorno		
77	Plug 13mm (5x)	Bouchon 13mm (5x)	Tappo 13mm (5x)		
78	O-ring 12,5x3 WRAS / KTW (1x)	Joint torique 12,5 x3 WRAS / KTW (1x)	O-ring 12,5x3 WRAS / KTW (1x)		
79	Clip 13mm	Clip de sécurité 13mm (1X)	Molletta di ritenzione 13mm		
80	Clip 10mm (10x)	Épingle D10 (x10)	Molletta di ritenzione 10mm (10x)		
4B	Element of construction	Groupe d'assemblage	Gruppo di montaggio		
1	Pump UPM4L 68W ErP1 (Cast iron)	Pompe UPM4L 68W ErP1 (Fonte)	Pompa UPM4L 68W ErP1 (Ghisa)		

Übersetzungsliste
List of translations

Liste des traductions
Traduzione delle descrizioni

Pos	Description	Description	Descrizione		
1	Pump UPM4L 75W ErP1 (Cast iron)	Pompe UPM4L 75W ErP1 (Fonte)	Pompa UPM4L 75W ErP1 (Ghisa)		
2	Siphon	Siphon	Sifone		
4	Cap	Couvercle	Coperchio		
5	Seal	Joint siphon	Guarnizione		
6	Pressure relief valve	Soupape de limitation de pression	Valvola di sicurezza		
10	Drain hose	Tuyau d'évacuation	Tubo flessibile di scarico		
14	Supply pipe (2 pieces)	Tube départ (en 2 parties)	Tubo di mandata (2 pezzi)		
14	Supply pipe	Tube départ	Tubo di mandata		
15	Pressure Gauge	Manomètre	Manometro		
16	Air vent	Soupape de ventilation	Disaeratore		
18	Gasket 22,2x30x2	Joint 22,2x30x2	Guarnizione 22,2x30x2		
20	O-ring 17x4 L (10x)	Joint torique 17x4 L (10x)	O-ring 17x4 L (10x)		
21	Clip (10x)	Clip pour tuyau (x10)	Clip a innesto (10x)		
22	Union nut	Écrou-union	Ghiera filettata		
26	Clip 18mm (10x)	Épingle 18mm (10x)	Molletta di ritenzione 18mm (10x)		
28	Temperature Sensor	Sonde de température	Sonda di temperatua		
32	Gasket 25x30x1,5 (10x)	Joint 30x25x1,5 (10x)	Guarnizione 30x25x1,5 (10x)		
33	Pressure Sensor	Capteur de pression	Sonda di pressione		
42	O-ring 2,62x6,02 WRAS / KTW (10x)	Joint torique 2,62x6,02 WRAS / KTW (10x)	O-ring 2,62x6,02 WRAS / KTW (10x)		
43	Return manifold	Raccordement retour	Collegamento ritorno		
80	Clip 10mm (10x)	Épingle D10 (x10)	Molletta di ritenzione 10mm (10x)		
87	O-ring 7,75x2,1 (10x)	Joint torique 7,75x2,1 (10x)	O-ring 7,75x2,1 (10x)		
4C	Element of construction	Groupe d'assemblage	Gruppo di montaggio		
1	Pump UPM4L 68W ErP1	Pompe UPM4L 68W ErP1	Pompa UPM4L 68W ErP1		
2	Siphon	Siphon	Sifone		
4	Cap	Couvercle	Coperchio		
5	Seal	Joint siphon	Guarnizione		
6	Pressure relief valve	Soupape de limitation de pression	Valvola di sicurezza		
10	Drain hose	Tuyau d'évacuation	Tubo flessibile di scarico		
12	O-ring 20,22x3,53 EPDM (10x)	Joint torique 20,22x3,53 EPDM (10x)	O-ring 20,22x3,53 EPDM (10x)		
14	Supply pipe	Tube départ	Tubo di mandata		
15	Pressure Gauge	Manomètre	Manometro		

Übersetzungsliste
List of translations

Liste des traductions
Traduzione delle descrizioni

Pos	Description	Description	Descrizione		
16	Air vent	Soupape de ventilation	Disaeratore		
18	Gasket 22,2x30x2	Joint 22,2x30x2	Guarnizione 22,2x30x2		
20	O-ring 17x4 L (10x)	Joint torique 17x4 L (10x)	O-ring 17x4 L (10x)		
21	Clip (10x)	Clip pour tuyau (x10)	Clip a innesto (10x)		
26	Clip 18mm (10x)	Épingle 18mm (10x)	Molletta di ritenzione 18mm (10x)		
27	Return pipe CH	Tube retour	Tubo di ritorno		
28	Temperature Sensor	Sonde de température	Sonda di temperatua		
29	Supply pipe CH	Tube départ CH	Tubo di mandata CH		
33	Pressure Sensor	Capteur de pression	Sonda di pressione		
35	3-way valve	Vanne 3 voies	Organo 3 vie		
38	Plug 18mm	Bouchon 18mm	Tappo 18mm		
40	Solar Pipe cold	Tube solaire	Tubo di solare		
41	Supply pipe (Solar)	Tube départ (Solar)	Tubo di mandata (Solar)		
42	O-ring 2,62x6,02 WRAS / KTW (10x)	Joint torique 2,62x6,02 WRAS / KTW (10x)	O-ring 2,62x6,02 WRAS / KTW (10x)		
48	Clip (10x)	Clip (10x)	Clip a innesto (10x)		
52	Gasket 23,9x17,2x1,5 (10x)	Joint 23,9x17,2x1,5 (10x)	Guarnizione 23,9x17,2x1,5 (10x)		
54	O-ring 23x4 (10x)	Joint torique 23x4 (10x)	O-ring 23x4 (10x)		
55	O-ring 23,47x2,62 (10x)	Joint torique 23,47x2,62 (10x)	O-ring 23,47x2,62 (10x)		
56	Connecting pipe (Pressure relief valve)	Tube de raccordement (Soupape sécurité)	Tubo di collegamento (Valvola sicurezza)		
58	Fill and drain cock	Robinet de remplissage et de vidange	Rubinetto di carico e scarico		
59	Seal 19.9mm (1x)	Joint 19.9mm (1x)	Guarnizione 19.9mm (1x)		
60	Manifold plate (Pump)	Collecteur (Pompe)	Collettore (Pompa)		
61	Manifold	Raccordement	Collegamento		
62	Motor (3-way valve)	Servomoteur (vanne 3 voies)	Motore (Organo 3 vie)		
63	Screw M5x30 + Washer	Vis et joint rondelle M5x30	Vite M5x30 + Rondella		
64	Clip (10x)	Clip (10x)	Clip di fissaggio (10x)		
65	O-ring 34x3 (10x)	Joint torique 34x3 (10x)	O-ring 34x3 (10x)		
68	Clip (10x)	Epingle (10x)	Molletta di ritenzione (10x)		
70	Plug 15mm	Bouchon 15mm	Tappo 15mm		
71	Supply pipe DHW	Tube départ	Tubo di mandata		
72	Supply pipe DCW	Tube départ	Tubo di mandata		
73	Return pipe	Tube retour	Tubo di ritorno		

Übersetzungsliste
List of translations

Liste des traductions
Traduzione delle descrizioni

Pos	Description	Description	Descrizione		
77	Plug 13mm (5x)	Bouchon 13mm (5x)	Tappo 13mm (5x)		
78	O-ring 12,5x3 WRAS / KTW (1x)	Joint torique 12,5 x3 WRAS / KTW (1x)	O-ring 12,5x3 WRAS / KTW (1x)		
79	Clip 13mm	Clip de sécurité 13mm (1X)	Molletta di ritenzione 13mm		
80	Clip 10mm (10x)	Épingle D10 (x10)	Molletta di ritenzione 10mm (10x)		
81	O-ring 6x2,5 (10x)	Joint torique 6x2,5 (x10)	Anello tenuta 6x2,5 (10x)		
84	Mixing valve	Vanne mélangeuse	Valvola miscelatrice		
86	Plug 10mm	Bouchon 10mm	Tappo 10mm		
87	O-ring 7,75x2,1 (10x)	Joint torique 7,75x2,1 (10x)	O-ring 7,75x2,1 (10x)		
88	Pipe (Heat exchanger)	Tube (Échangeur thermique)	Tubo (Scambiatore di calore)		
91	Clip (10x)	Clip (10x)	Clip di fissaggio (10x)		
5	Element of construction	Groupe d'assemblage	Gruppo di montaggio		
1	Ignition transformer	Transformateur d'allumage	Trasformatore d'accensione		
2	Ignition cable	Câble d'allumage	Cavo d'accensione		
3	Earth cable L 140mm	Câble de mise à la terre L 140mm	Cavo di massa L 140mm		
4	Grommet (Cable guide)	Passe-fil (Guide de câble)	Anello di gomma (Passaggio cavi)		
8	Mains cable	Câble d'alimentation	Cavo di alimentazione		
9	Collar	Gaine	Guaina		
13	Cable + Switch ON/OFF	Module MHM avec "ON OFF	Cavo + Interruttore ON/OFF		
16	Pump cable	Câble pompe	Cavo pompa		
17	Cable harness LV	Faisceau de câbles LV	Cablaggio LV		
18	Cable harness LV	Faisceau de câbles LV	Cablaggio LV		
19	Cable harness HV	Faisceau de câbles 230V	Cablaggio HV		
20	Cable harness HV	Faisceau de câbles HV	Cablaggio HV		
21	Cable harness LV	Faisceau de câbles LV	Cablaggio LV		
22	Cable harness LV	Faisceau de câbles LV	Cablaggio LV		
6	Element of construction	Groupe d'assemblage	Gruppo di montaggio		
1	System controller UI800-GC	Contrôleur système UI800-GC	Controller di sistema UI800-GC		
2	Control unit ACU MHP-20	Tableau électrique ACU MHP-20	Centralina ACU MHP-20		
3	Support (Control unit)	Support (Tableau électrique)	Supporto (Centralina)		
4	Strain Relief	Serre-câble	Ferma cavo		
5	Cover (Installer Access)	Couvercle (accès installateur)	Copertura (Accesso installatore)		
6	Cover (Ip PluX)	Cache (Ip PluX)	Copertura (Ip PluX)		

Übersetzungsliste
List of translations

Liste des traductions
Traduzione delle descrizioni

Pos	Description	Description	Descrizione		
7	Lock (PluX)	Verrou (PluX)	Chiusura (PluX)		
8	Grommet feed 2-pole	Passe-câbles 2-pôles	Passacavo 2-bipolare		
9	Fastener (2x)	Clip de fixation du support d'attache X2	Gancio di chiusura (2x)		
11	Fuse Holder	Support de fusible	Porta fusibile		
12	Fuse 5x20mm Fast Acting (5x)	Fusible 5x20mm Fast Acting (5x)	Fusibile 5x20mm Fast Acting (5x)		
13	Code plug 20347 20 P 23	HCM 20347 20 P 23	HCM 20347 20 P 23		
13	Code plug 20345 30 P 23	HCM 20345 30 P 23	HCM 20345 30 P 23		
13	Code plug 20350	HCM 20350	HCM 20350		
13	Code plug 20349	HCM 20349	HCM 20349		
13	Code plug 20357 20 P RR	HCM 20357 20 P RR	HCM 20357 20 P RR		
13	Code plug 20355 30 P RR	HCM 20355 30 P RR	HCM 20355 30 P RR		
13	Code plug 20353	HCM 20353	HCM 20353		
13	Code plug 20397	HCM 20397	HCM 20397		
14	Connector 2-Pole (Pure Orange) RAL2004	Connecteur 2-pôles (orangé pur) RAL2004	Morsetto 2-pol (arancio puro) RAL2004		
15	Connector 2-pole (light blue) RAL5012	Connecteur 2-pôles (bleu clair) RAL5012	Morsetto 2-pol (blu luce) RAL5012		
16	Connector 2-Pole (Signal Blue) RAL5005	Connecteur 2-pôles(bleu sécurité)RAL5005	Morsetto 2-pol (blu segnale) RAL5005		
17	Connector 2-pole (yellow green) RAL6018	Connecteur 2-pôles (vert jaune) RAL6018	Morsetto 2-pol (verde giallastro)RAL6018		
18	Connector 2-pole (silver grey) RAL7001	Connecteur 2-pôles (gris argent) RAL7001	Morsetto 2-pol (grigio argento) RAL7001		
19	Connector 2-pole (graphite grey) RAL7024	Connecteur 2-pôles(gris graphite)RAL7024	Morsetto 2-pol (grigio grafite) RAL7024		
20	Connector 2-pole (pastel violet) RAL4009	Connecteur 2-pôles(violet pastel)RAL4009	Morsetto 2-pol(violetto pastello)RAL4009		
21	Connector 2-pole (signal green) RAL6032	Connecteur 2-pôles(vert sécurité)RAL6032	Morsetto 2-pol (verde segnale) RAL6032		
24	Connector 2-pole (cream) RAL9001	Connecteur 2-pôles (blanc crème) RAL9001	Morsetto 2-pol (bianco crema) RAL9001		
25	Connector 2-pole (red violet) RAL4001	Connecteur 2-pôles (violet rouge)RAL4001	Morsetto 2-pol (viola rossastro) RAL4001		
26	Connector 2-pole (orange brown) RAL8023	Connecteur 2-pôles (brun orangé) RAL8023	Morsetto 2-pol (marrone arancio) RAL8023		
27	Screw M5x12 (10x)	Vis M5x12 (10x)	Vite M5x12 (10x)		
28	Connector kit	Jeu de connecteurs	Set morsetti di collegamento		
29	Outdoor temperature sensor	Sonde de température extérieure	Sonda temperatua esterna		
	LAN and radio module K 40 RF Bosch	K40 RF	Connect Key K40 RF+wifi+LAN		

Gerätetypen
Types of appliances

Types de chaudières
Tipo apparecchi

Gerät Appliance Chaudière Apparecchio	Bestell-Nr. Ordering no. Numéro de commande N° d'ordine	Land Country Pays Paese	Bemerkungen Remarks Remarques Osservazioni
GC9800iW 20 H 23	7 738 101 028	AT,DE,LU	
GC9800iW 20 P 23	7 738 101 024	AT,DE,LU	
GC9800iW 30 H 23	7 738 101 029	AT,DE,LU	
GC9800iW 30 P 23	7 738 101 025	AT,DE,LU	
GC9800iW 40 H 23	7 738 101 030	AT,DE,LU	
GC9800iW 50 H 23	7 738 101 031	AT,DE,LU	
GC9800iW 20 P 23	7 724 002 658	CH	
GC9800iW 30 P 23	7 724 002 659	CH	
GC9800iWA 20 P 23	7 738 101 026	DE,LU	
GC9800iWA 30 P 23	7 738 101 027	DE,LU	



BOSCH

Bosch Thermotechnik GmbH
Junkersstr. 20-24
D-73249 Wernau / Germany
www.bosch-homecomfort.com